

Rolling Bridge Jacks

Installation and Operation Manual

Manual P/N 5900004 — Manual Revision D1 — Released October 2020

Models:

- RBJ15000
- RBJ18000
- RBJ25000



Designed and engineered by BendPak Inc. in Southern California, USA. Made in China.

 **DANGER**

Read the *entire contents* of this manual *before* using this product. Failure to follow the instructions and safety precautions in this manual can result in serious injury or death. Make sure all other operators also read this manual. Keep the manual near the product for future reference. *By proceeding with setup and operation, you agree that you fully understand the contents of this manual and assume full responsibility for product use.*

Manual. RBJ Series of Rolling Bridge Jacks, *Installation and Operation Manual*, Manual Part Number 5900004, Manual Revision D1, Released October 2020.

Copyright. Copyright © 2020 by BendPak Inc. All rights reserved. You may make copies of this document if you agree that: you will give full attribution to BendPak Inc., you will not make changes to the content, you do not gain any rights to this content, and you will not use the copies for commercial purposes.

Trademarks. BendPak and the BendPak logo are registered trademarks of BendPak Inc. All other company, product, and service names are used for identification only. All trademarks and registered trademarks mentioned in this manual are the property of their respective owners.

Limitations. Every effort has been made to ensure complete and accurate instructions are included in this manual. However, product updates, revisions, and/or changes may have occurred since this manual was published. BendPak reserves the right to change any information in this manual without incurring any obligation for equipment previously or subsequently sold. BendPak is not responsible for typographical errors in this manual. The latest version of this manual is always available on [the BendPak website](#).

Warranty. The BendPak warranty is more than a commitment to you: it is also a commitment to the value of your new product. Contact your nearest BendPak dealer or visit www.bendpak.com/support/warranty for full warranty details. Go to bendpak.com/support/register-your-product/ and fill out the online form to register your product (be sure to click **Submit**).

Safety. Your new product was designed and manufactured with safety in mind. Your safety also depends on proper training and thoughtful operation. Do not set up, operate, maintain, or repair the unit without reading and understanding the safety information in this manual and the labels on the unit. Contact BendPak if you are unclear about any safety aspect of this product; ***do not use this product unless you can do so safely!***

Owner Responsibility. In order to maintain your product properly and to ensure operator safety, it is the responsibility of the product owner to read and follow these instructions:

- Follow all setup, operation, and maintenance instructions.
- Make sure product setup conforms to all applicable local, state, and federal codes, rules, and regulations, such as state and federal OSHA regulations and electrical codes.
- Read and follow all safety instructions. Keep them readily available for operators.
- Make sure all operators are properly trained, know how to safely operate the unit, and are properly supervised.
- Do not operate the product until you are certain all parts are in place and operating correctly.
- Carefully inspect the product on a regular basis and perform all maintenance as required.
- Service and maintain the unit only with approved replacement parts.
- Keep all instructions permanently with the product and make sure all labels are clean and visible.
- **Only use this product if it can be used safely!**

Unit Information. Enter the Model Number, Serial Number, and the Manufactured On date from the label on your unit. This information is required for part or warranty issues.

Model: _____

Serial: _____

Manufactured On: _____

Table of Contents

Introduction	3	Operation	19
Shipping Information	4	Maintenance	23
Safety Considerations	4	Troubleshooting	24
Components	6	Accessories	25
FAQ	8	Labels	26
Specifications	9	Parts Sheets	27
Setup	10		

Introduction

This manual covers the RBJ Series of Rolling Bridge Jacks, which are used on four-post Lifts to raise two or four wheels off the Runway of the Lift, making automotive service such as brake jobs and suspension work easier to accomplish.

This manual covers the following RBJ models:

- **RBJ15000**: Raises up to 15,000 lbs / 6,804 kg. For BendPak HDS-27 and HDS-27X Lifts.
- **RBJ18000**: Raises up to 18,000 lbs / 8,165 kg. For BendPak HDS-35 and HDS-35X Lifts.
- **RBJ25000**: Raises up to 25,000 lbs / 11,340 kg. For BendPak HDS-40 and HDS-40X Lifts.

BendPak also makes Rolling Jacks with 4,500, 6,000, 7,000, and 9,000 pound capacities; those models are covered in a **separate manual available on the BendPak website**.

This manual is mandatory reading for all users of these Rolling Bridge Jacks, including anyone who installs, operates, maintains, or repairs them.

 **DANGER** Be very careful when installing, operating, maintaining, or repairing your unit; failure to do so could result in property damage, product damage, injury, or (in very rare cases) death. Make sure only authorized personnel operate the unit. All repairs must be performed by an authorized technician. Do not make modifications to the unit; this voids the warranty and increases the chances of injury or property damage. Make sure to read and follow the instructions on the labels on the unit.

Keep this manual on or near the equipment so that anyone who uses or services it can read it.

If you are having issues, refer to the **Troubleshooting** section of this manual for assistance.

Technical support and service is available from your dealer, on the Web at **bendpak.com/support**, by email at **support@bendpak.com**, or by phone at **(800) 253-2363**, extension 196.

You may also contact BendPak for parts replacement information (please have the model and serial number of your unit available) at **(800) 253-2363**, extension 191.

Shipping Information

Your unit was carefully checked before shipping. Nevertheless, you should thoroughly inspect the shipment before you sign to acknowledge that you received it.

When you sign the bill of lading, it tells the carrier that the items on the invoice were received in good condition. To protect yourself, do not sign the bill of lading until after you have inspected the shipment. If any of the items listed on the bill of lading are missing or are damaged, do not accept the shipment until the carrier makes a notation on the bill of lading that lists the missing and/or damaged goods.

If you discover missing or damaged goods after you receive the shipment and have signed the bill of lading, notify the carrier at once and request the carrier to make an inspection. If the carrier will not make an inspection, prepare a signed statement to the effect that you have notified the carrier (on a specific date) and that the carrier has failed to comply with your request.

It is difficult to collect for loss or damage after you have given the carrier a signed bill of lading. If this happens to you, file a claim with the carrier promptly. Support your claim with copies of the bill of lading, freight bill, invoice, and photographs, if available. Our willingness to assist in helping you process your claim does not make us responsible for collection of claims or replacement of lost or damaged materials.

Safety Considerations

Read this manual carefully before using your new product. Do not set up or operate the product until you are familiar with all operating instructions and warnings. Do not allow anyone else to operate the product until they are also familiar with all operating instructions and warnings.

Rolling Bridge Jack Safety Information

Please note the following:

- The product is a Rolling Bridge Jack. Use it only for its intended purpose.
- The product should only be operated by trained, authorized personnel.
- When the product is in use, keep all body parts away from it.
- Do not make any modifications to the product.

 **WARNING** When the Rolling Bridge Jack is on a raised Lift, **do not go under it!** If you notice a Roller out of position, get everyone away from the Lift, lower the Lift, reposition the Rollers back into the Utility Rail Channel, and then make sure the unit is correctly installed and adjusted.

- Make sure all operators read and understand this *Installation and Operation Manual*. Keep the manual near the device at all times.
- Make a visual inspection of the product before using it every time. Check for missing or damaged parts. Do not use the product if you find any of these issues. Instead, take the Jack out of service, then contact an authorized repair facility, your distributor, or BendPak at **(800) 253-2363**.
- Make a thorough inspection of the product at least once a year. Replace any damaged or severely worn cables, hydraulic hoses, decals, or warning labels. Do not use the product until worn or damaged items have been replaced.
- Do not touch hot parts; you could be burned.
- Take care locating cables and hoses; you do not want them driven over or stepped on.

-
- Always wear steel-toed footwear and safety glasses when using the Jack.
 - Clear the area immediately if a Vehicle is in danger of falling off the Rolling Bridge Jack.
 - ***Make sure the Rolling Bridge Jack is engaged on Safety Locks before starting work.***
 - Operating temperature for a Rolling Bridge Jack is 41°F to 104°F (5°C to 40°C).
 - Make sure the weight of the Vehicle being raised by a Rolling Bridge Jack does not exceed its maximum lifting capacity.

Symbols

Following are the symbols used in this manual:

 **DANGER** Calls attention to an immediate hazard that **will** result in death or severe injury.

 **WARNING** Calls attention to a hazard or unsafe practice that **could** result in death or severe personal injury.

 **CAUTION** Calls attention to a hazard or unsafe practice that could result in minor personal injury, product, or property damage.

NOTICE Calls attention to a situation that, if not avoided, could result in product or property damage.



Tip

Calls attention to information that can help you use your unit better.

Liability Information

BendPak assumes **no** liability for damages resulting from:

- Use of the equipment for purposes other than those described in this manual.
- Modifications to the equipment without prior, written permission from BendPak.
- Injury or death caused by modifying, disabling, overriding, or removing safety features.
- Damage to the equipment from external influences.
- Incorrect operation of the equipment.

Components

Rolling Bridge Jack components include:

- **Scissor Structure.** Rolling Bridge Jacks are scissor lifts that are powered by air pressure from the Air-Operated Hydraulic Pump.
- **Air-Operated Hydraulic Pump.** Provides hydraulic power to the Rolling Bridge Jack. The Air-Operated Hydraulic Pump must be attached to a dry air supply: 20 cubic feet per minute (.57 cubic meters per minute) and 100 psi (7 bar).
- **Hydraulic Hose.** Connects the Air-Operated Hydraulic Pump to the Hydraulic Cylinder. Comes connected from the factory.
- **Hydraulic Cylinder.** Moves the Scissor Structure up and down.
- **Safety Locks.** Hold the Rolling Bridge Jack in place once engaged at the desired height (two heights available). Always leave your Rolling Bridge Jack either fully lowered or engaged on its Safety Locks. ***Do not leave a Rolling Bridge Jack in an unlocked position with a Vehicle on it.***

 **WARNING** Before starting work on a Vehicle, make sure the Rolling Bridge Jack is engaged on its Safety Locks and the Pads are in contact with the axle on the underside of the Vehicle.

- **Safety Handle.** Moves the Rolling Bridge Jack off its Safety Locks so it can be lowered. *Not the same as the Handle you use to move the Rolling Bridge Jack.*
- **Adjustable Arms.** Slide in and out so you can use the Fixed Pads at appropriate locations under the Vehicle.
- **Receiver Plate.** Holds the Sliding Pads on the outside and the Adjustable Arms on the inside. Part of the structure of the Rolling Bridge Jack.
- **Fixed Pads.** Steel Pads that go on the ends of the Adjustable Arms. All three Rolling Bridge Jacks come with two sets of Fixed Pads.
- **Sliding Pads.** Steel Pads that slide over the Receiver Plate and can be used anywhere along it. All three Rolling Bridge Jacks come with two sets of Sliding Pads.
- **Handles (2).** Used to move the Rolling Bridge Jack. *Not the same as the Safety Handle.*
- **Extendable Bases.** Move in and out to accommodate the distance between the Lift's Runways. Only the RBJ15000 has Extendable Bases.
- **Channel Rollers.** Located on the ends of the Bases, the Channel Rollers sit in the Utility Rail Channel and let you move the Rolling Bridge Jack along the Utility Rail.
- **Adjustment Bolts.** RBJ15000 only. A safety feature, they hold the Extendable Bases in place. ***Installation is mandatory.***

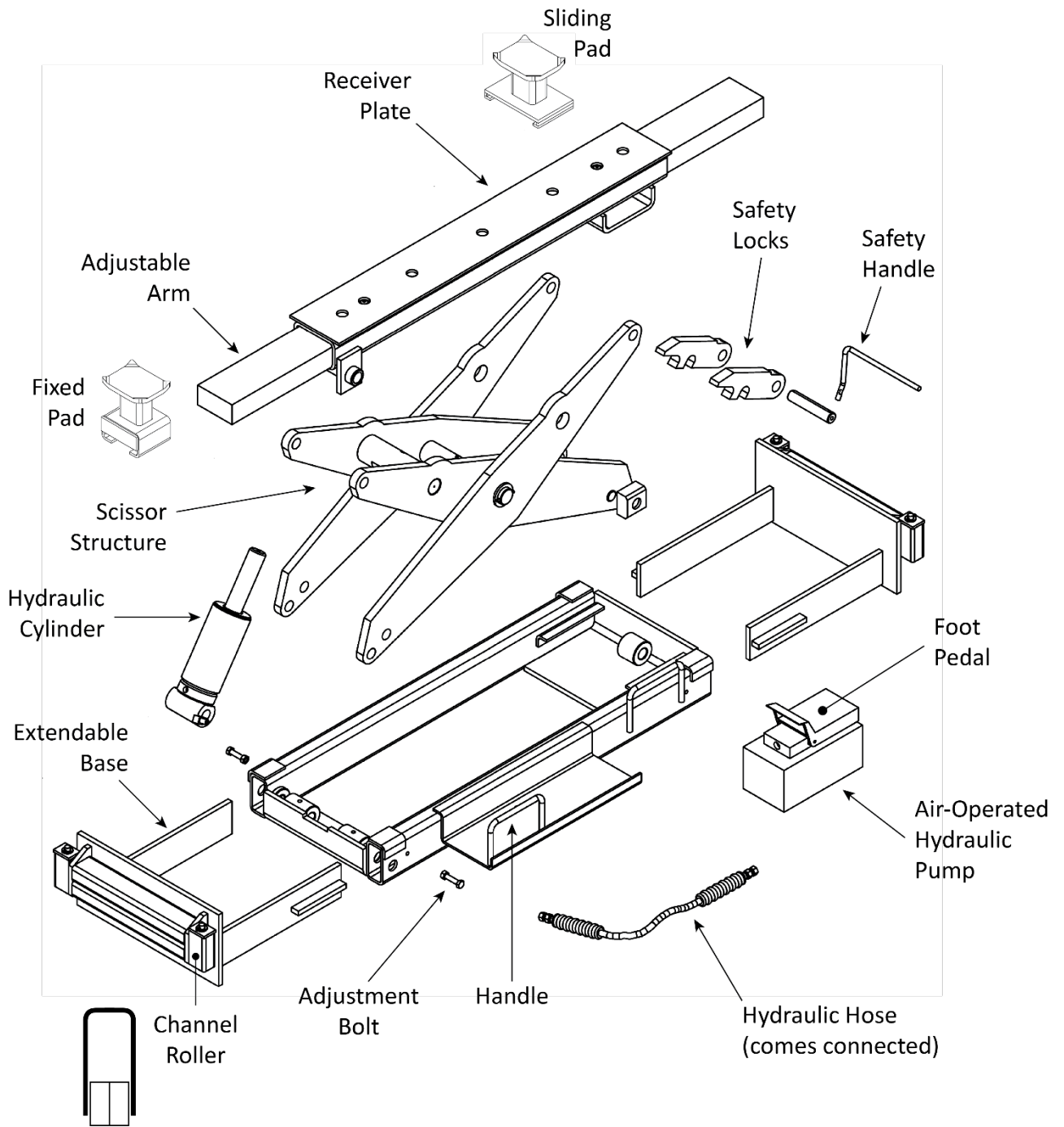

Model RBJ15000 shown. Not necessarily to scale. Not all components shown. Only the RBJ15000 has Extendable Bases and Adjustment Bolts; the RBJ18000 and RBJ25000 do not.

Frequently Asked Questions

Question: What kinds of Vehicles can I raise on my Rolling Bridge Jack?

Answer: A wide range of Vehicles. There are multiple Rolling Bridge Jack models, each supporting different weight capacities, so a wide range of Vehicles can be raised.

Q: If a Vehicle is already on a Lift, why do I need a Rolling Bridge Jack?

A: A Rolling Bridge Jack gives you the option of raising two or four wheels of the Vehicle off the Runway of the Lift, which makes certain automotive services (brake jobs, suspension work, tire changes, and so on) much easier. To get **four wheels** off the Runway, you need **two Rolling Bridge Jacks**.

Q: How does a Rolling Bridge Jack work?

A: Each Rolling Bridge Jack gets positioned between the Runways of a four-post Lift, such as an HDS-27. They are used to raise the front or the rear Wheels of the Vehicle up off the Runway, via their axles. Having the Wheels off the Runway makes it easier to perform certain automotive services.

Q: What Rolling Bridge Jack goes with what BendPak Lift?

A: Rolling Bridge Jacks are associated with specific BendPak Lifts, based on their weight capacities. The RBJ15000 goes on HDS-27 and HDS-27X models. The RBJ18000 goes on HDS-35 and HDS-35X models. The RBJ25000 goes on HDS-40 and HDS-40X models.

Q: Are Rolling Bridge Jacks heavy?

A: Yes. You need a Shop Crane or Forklift to put them into position and you must **not** stand or walk under them. Your Rolling Bridge Jack was designed to stay in place, but you should always use extreme care when walking around under Lifts, raised Vehicles, and Rolling Bridge Jacks.

Q: Are the bases of my Rolling Bridge Jack extendable?

A: If it is an RBJ15000, then Yes. The bases for the RBJ18000 and the RBJ25000, however, are **not** extendable.

Q: How is a Rolling Bridge Jack powered?

A: Via air pressure (that you supply) that connects to the Air-Operated Hydraulic Pump. The optional Air Line Kit makes this easy; visit [the website page](#) for more information.

Q: How many Safety Lock positions does my Rolling Bridge jack have?

A: Two. This gives you two heights to which you can raise your Rolling Bridge Jack.

Q: How long can I leave a Vehicle raised on my Rolling Bridge Jack?

A: For quite some time, as long as long as you leave it engaged on its Safety Locks. Once the Jack is engaged on its Safety Locks, gravity holds it up, so a loss of air pressure has no impact; the Jack and the Vehicle are going to stay where you left them. **Always leave your Rolling Bridge Jack either fully lowered or engaged on Safety Locks.**

Specifications

Model	RBJ15000	RBJ18000	RBJ25000
Lifting capacity	15,000 lbs / 6,804 kg	18,000 lbs / 8,165 kg	25,000 lbs / 11,340 kg
Min. Drive-Over Height (with Short Arm Pad)	9" / 229 mm	9" / 229 mm	9" / 229 mm
Max. Lifting Height (with Short Arm Pad)	19" / 483 mm	19" / 483 mm	19" / 483 mm
Minimum arm reach	39.4" / 1,003 mm	39.6" / 1,008 mm	39.6" / 1,008 mm
Maximum arm reach	63.75" / 1,618 mm	63.5" / 1,612 mm	63.5" / 1,612 mm
Supported base widths	~45.75" / 1,163 mm to ~58.5" / 1,489 mm	~45" / 1,140 mm (fixed)	~45" / 1,140 mm (fixed)
Maximum operating hydraulic pressure	6,000 PSI	7,200 PSI	8,050 PSI
Shipping weight	698 lbs / 259 kg	777 lbs / 358 kg	819 lbs / 363 kg

Specifications are subject to change without notice.

About Vehicle Wheelbases

A BendPak four-post **Lift** supports less weight than its rated capacity when the wheelbase of the Vehicle on the Lift is shorter. This is because the wheels of these shorter wheelbase Vehicles are closer to the middle of the Runways, where there is less strength. Consequently, the rated capacity of that Lift is less for these shorter wheelbase Vehicles.

For example, if you want to raise a Vehicle with a wheelbase of 100" on an HDS-14LSX Lift, the rated capacity of the Lift is reduced by 50% to 7,000 lbs (3,175 kg).

Rated capacity information is included in the Specifications section in the manual of all four-post Lifts. Refer to the manual of a specific Lift for rated capacity information for that Lift.

This reduced capacity based on Vehicle wheelbase does not impact the rated capacity of the Rolling Bridge Jacks used on those Lifts. Nevertheless, make sure to always check the rated capacity of the Lift your Rolling Bridge Jacks are being used on to make sure you do not exceed the rated capacity of the Lift.

Setup

This section describes how to set up your Rolling Bridge Jack.

Safety Rules

When installing a Rolling Bridge Jack, your safety depends on proper training and thoughtful operation.

 **WARNING** Do not install this equipment unless you have installation training. Always use proper lifting tools, such as a Forklift or Shop Crane, to lift heavy components. Do not install this equipment without reading and understanding this manual and the safety labels on the unit.

Only fully trained personnel should be involved in installing this equipment. Pay attention at all times. Use appropriate tools and lifting equipment. Stay clear of moving parts.

 **WARNING** You must wear appropriate protective equipment during setup: leather gloves, steel-toed work boots, eye protection, back belts, and hearing protection.

Tools

You may need some or all of the following tools:

- Hex key wrench set
- Medium crescent wrench
- Forklift, Shop Crane, or other heavy lifting device
- Medium flat screwdriver
- Tape measure, 25 feet or longer
- Air fitting, to connect the Air-Operated Hydraulic Pump to air pressure

Preparing the Lift

Rolling Bridge Jacks go into the open space between the two Runways of the four-post Lift.

Keep the following in mind:

- **The Lift must be installed properly and operating normally.** Only use a Rolling Bridge Jack with a Lift that has been installed according to the manufacturer's instructions and is operating normally per those instructions.

 **WARNING** Do not set up or use a Rolling Bridge Jack if the Lift is not the model for which the Rolling Bridge Jack was designed or the Lift was improperly installed. Instead, contact the manufacturer of the Lift or BendPak Customer Service at (800) 253-2363 for instructions.

- **The Lift must be lowered.** Before situating your Rolling Bridge Jack, fully lower the Lift or engage it on its lowest Safety Lock position.



Tip

If you are going to be using a Crane to situate your Rolling Bridge Jack, you may need to lock the Lift on the lowest Safety Lock position to make room for the legs of the Crane.

- **You can only use the Rolling Bridge Jack in certain locations on the Lift.** This is because the strength of the Lift is less in the middle, so raising a Vehicle in the middle could permanently damage the Lift's Runways. In the vast majority of cases, this unusable area in the middle of the Lift will not impact your use of your Rolling Bridge Jacks, as the length of the wheelbases of the Vehicles you are raising will put the Rolling Bridge Jacks in the usable area.

⚠ CAUTION Using Rolling Bridge Jacks in the middle of the Lift could permanently damage the Lift's Runways. **Damage caused by this unsupported use of Rolling Bridge Jacks is not covered by the warranty.**

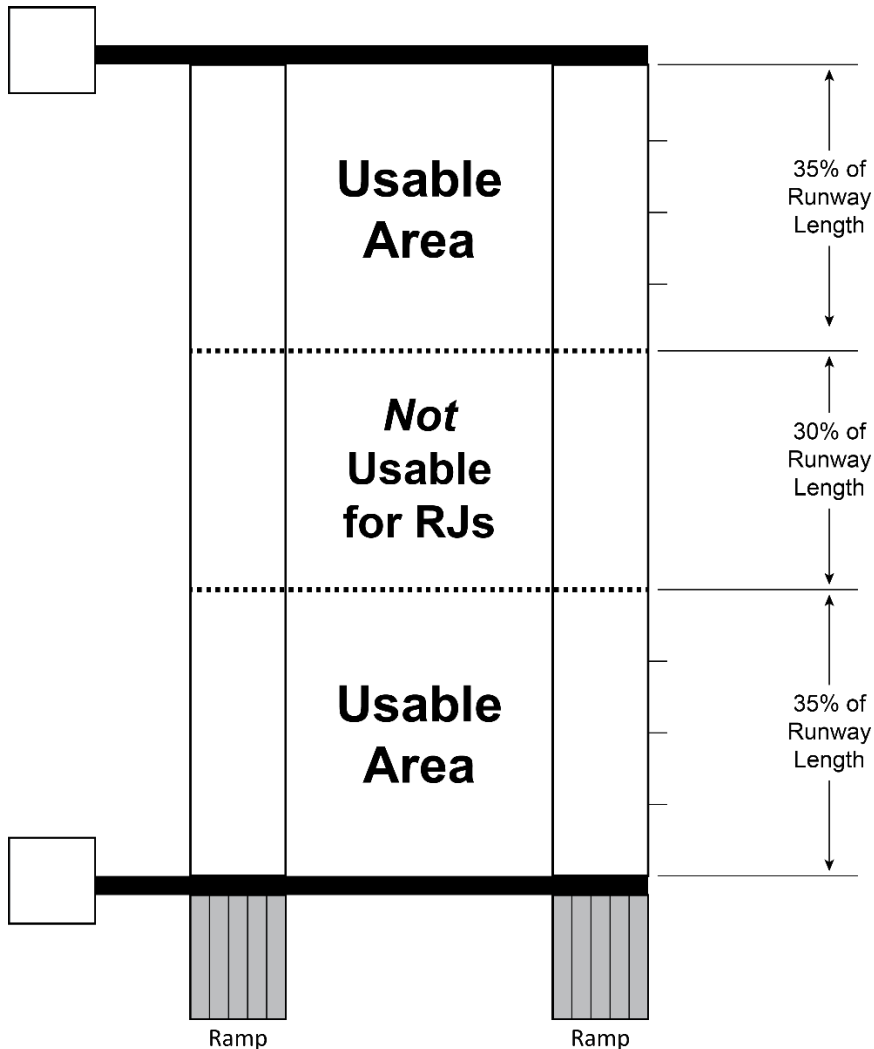

Not necessarily to scale. Not all components shown.

So what does this information mean:

- If you are using **one** Rolling Bridge Jack on your Lift, do not use it in the unusable area.
- If you are using **two** Rolling Bridge Jacks on your Lift, center the Vehicle between the Front and the Back of the Runways, over the area that is not usable for Rolling Bridge Jacks. This gives you the most room on the ends (the usable areas) for your Rolling Bridge Jacks.
- If you are using **two** Rolling Bridge Jacks, they must never be closer to each other than 30% of the length of the Runway of the Lift they are on, nor can either one be used in the unusable area.

Check the Specifications of your Lift for the length of the Runways and additional information.

- **The Lift Runways *must* be parallel.** Make sure the Lift Runways were installed parallel to each other. The distance between the Lift Runways ***must be equal*** along the entire length of the Lift.

In the following drawing, the distance between the Runways at Points A, B, and C ***must*** be the same. If they differ, moving the Rolling Bridge Jack will be much more difficult.

⚠ WARNING If the Lift Runways are ***not*** parallel, moving the Rolling Bridge Jack could force it off the Utility Rail, increasing the chances it could fall and be damaged or cause injury. If Lift Runways are not parallel, take the Lift out of service and get it adjusted so that the Lift Runways are parallel. Then you can use your Rolling Bridge Jack on the Lift.

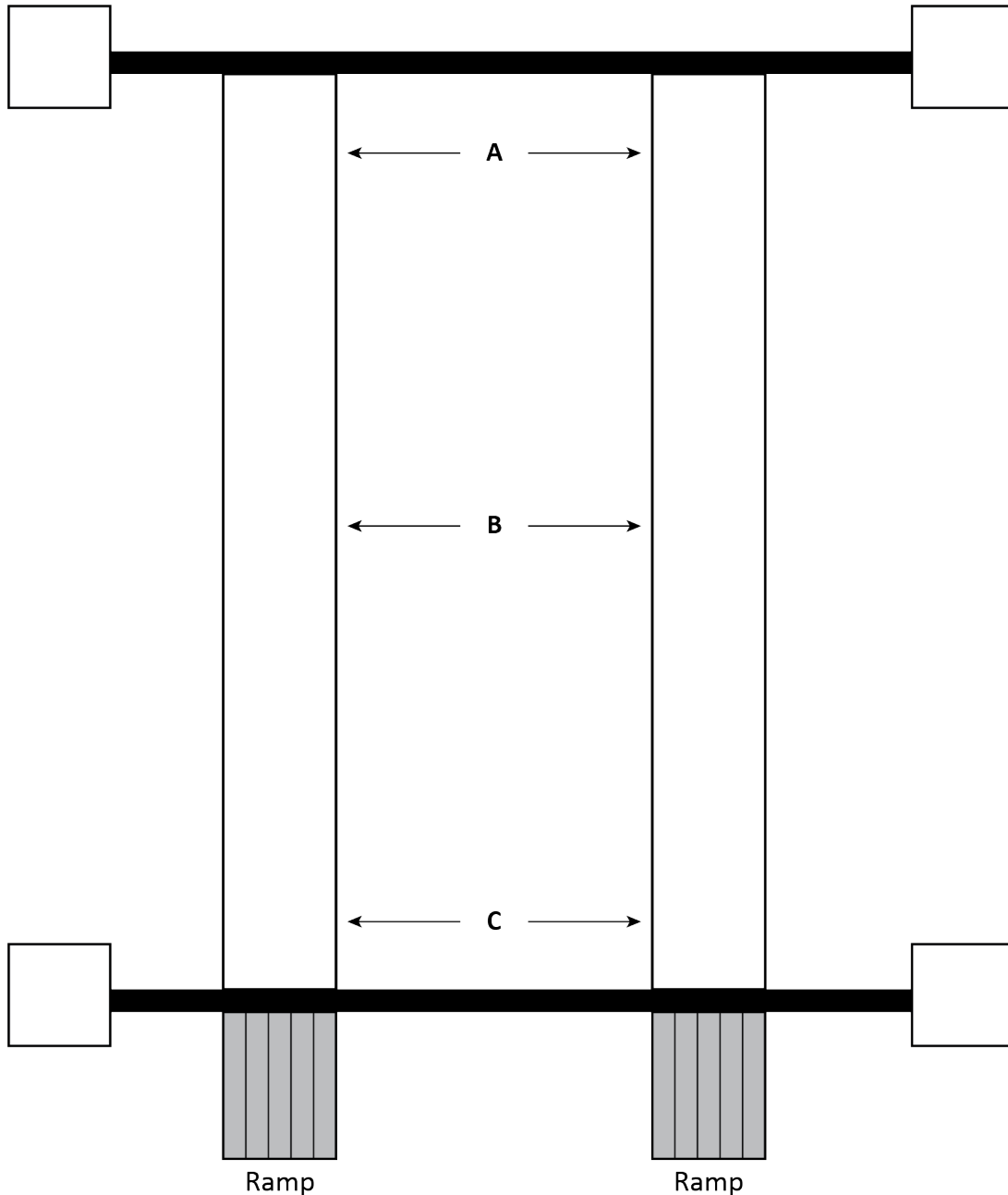

Not necessarily to scale. Not all components shown.

- **Orient the Air-Operated Hydraulic Pump correctly.** You need to orient each Rolling Bridge Jack such that the Air-Operated Hydraulic Pump is facing the Lift's Crosstube, the outside of the Lift. This makes it easier to route the integrated air lines and access the pump.

When using two Rolling Bridge Jacks on a Lift, orient both pumps towards the outside of the Lift.

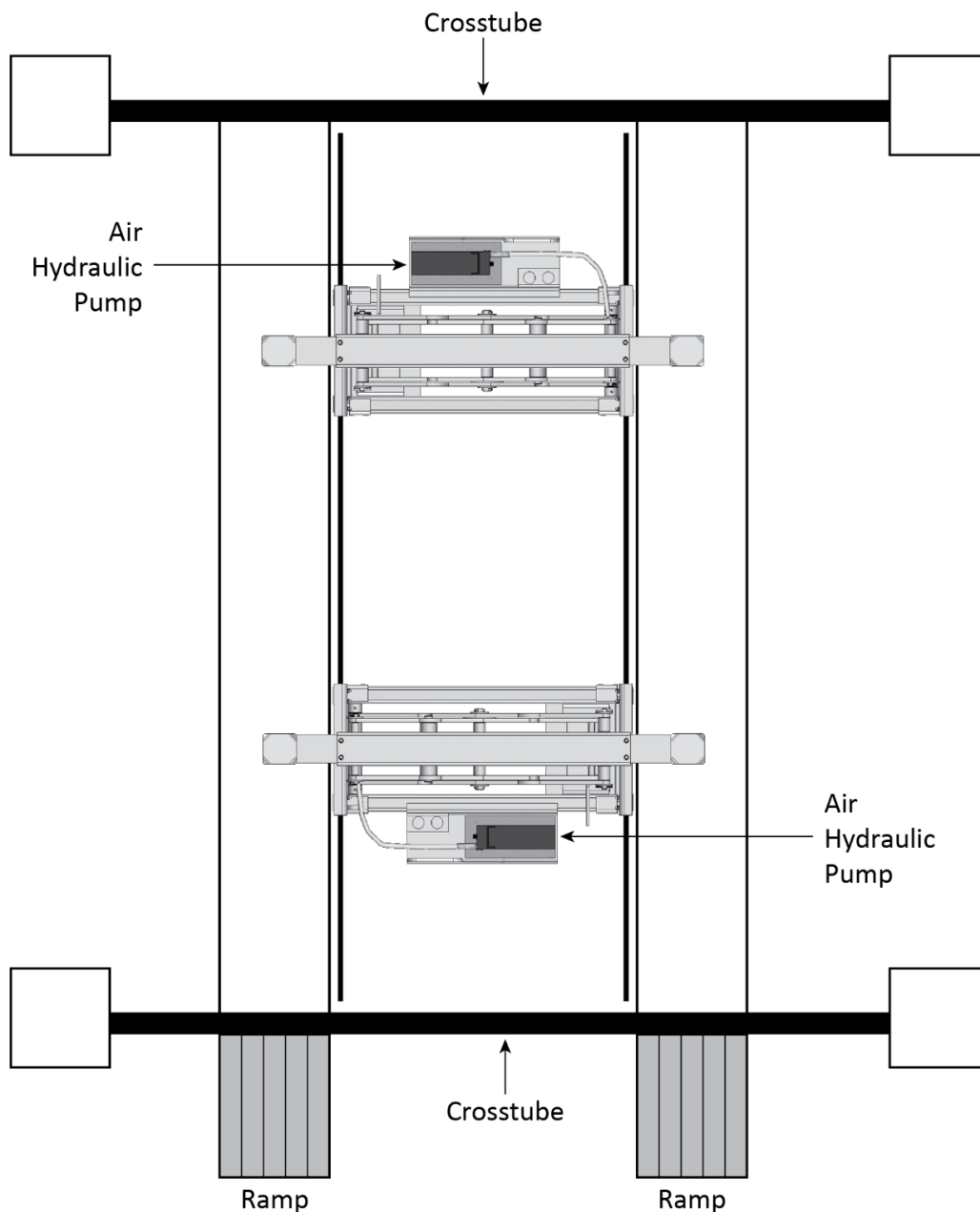

Drawing not necessarily to scale. Not all components shown.

Moving the Rolling Bridge Jack into Position

Rolling Bridge Jacks need to be moved into position using a Forklift, Shop Crane, or other device appropriate for lifting **heavy** loads.

⚠ WARNING Pay close attention when moving the Rolling Bridge Jack into position; it could shift, possibly causing injury. Prior to moving it, make sure the Rolling Bridge Jack is held **securely** by a Forklift, Shop Crane, or other device used for lifting heavy objects.

The following procedure includes instructions for all three Rolling Bridge Jacks: the RBJ15000, RBJ18000, and the RBJ25000.

The procedure is slightly different for the RBJ15000 because it has Extendable Bases and Adjustment Bolts, which the other two models do not.

To move a Rolling Bridge Jack into position on a Lift:

1. Make sure the **Lift** is either fully lowered or engaged on Safety Locks.
2. If you are installing an **RBJ18000** or **RBJ25000**, make sure the Lift's Runways are as far apart as possible.

Measure the distance between the two Runways to make sure they are ~47 inches / ~1,199 mm apart.

3. If you are installing an **RBJ15000**, set the Lift's Runways to the desired distance apart, from ~45.75 inches / 1,163 mm to ~58.5 inches / 1,489 mm.
4. Make sure the Utility Rail Channel is clear of all debris.

5. Using a Shop Crane, Forklift, or other lifting device, raise the Rolling Bridge Jack and orient it above and between the Lift's two Runways. **Do not lower it onto the Utility Rail yet.**

Remember to orient the Air-Operated Hydraulic Pump side appropriately: orient the Pump side of the Rolling Bridge Jack towards the Crosstubes/outside of the Lift (*not towards the inside*).

6. Lower the Rolling Bridge Jack to just above the Utility Rails between the Lift's Runways. **Do not lower it onto the Utility Rails yet.**

The following drawing shows the Channel Roller of an **RBJ18000** or **RBJ25000** sitting directly over the Utility Rail Channel.

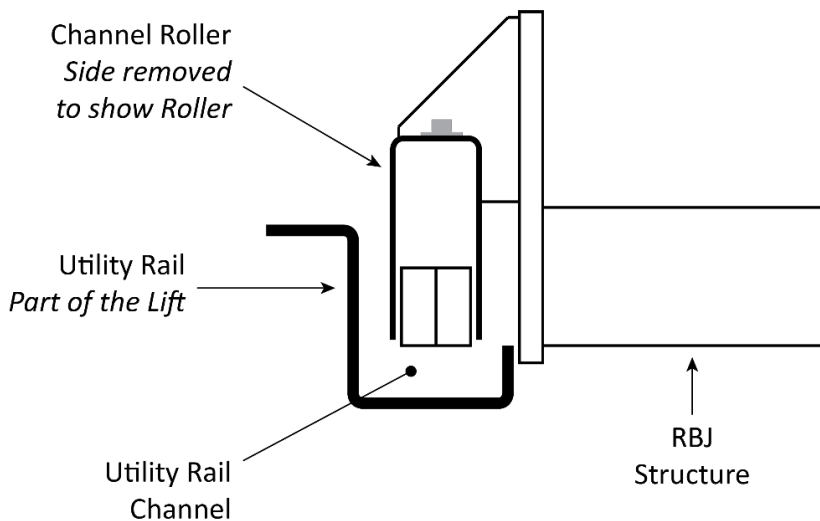

Not necessarily to scale. Not all components shown.

7. If you are installing an **RBJ15000**, adjust the Extendable Bases so the Channel Rollers are directly above the Channels on the Utility Rails.

The following drawing shows the Channel Roller of an **RBJ15000** being extended so that it is directly over the Utility Rail Channel. *Does not apply to RBJ18000 or RBJ25000.*

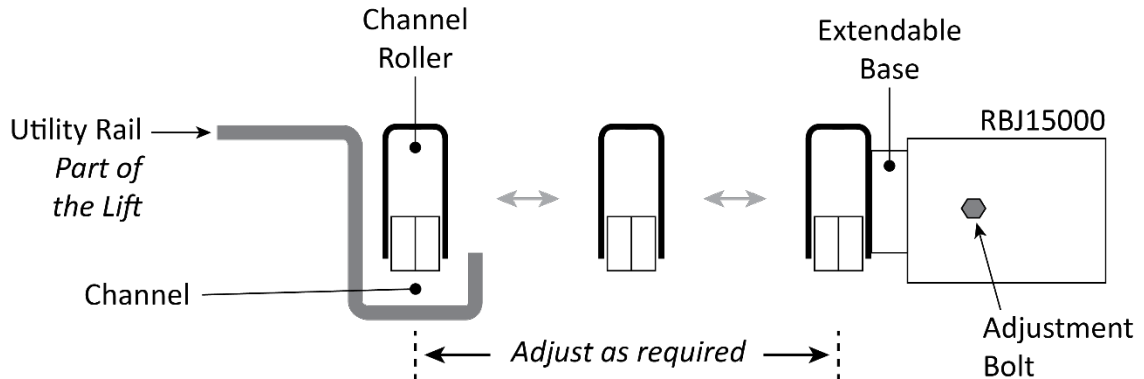

RBJ15000 only. Not necessarily to scale. Not all components shown.

8. Lower the Channel Rollers down into the Utility Rail Channel.
9. If you installing an **RBJ15000**, when the Rolling Bridge Jack is correctly situated in the Utility Rail Channel, securely tighten all four Adjustment Bolts.

⚠ WARNING You are **required** to fully tighten all four Adjustment Bolts on an RBJ15000. They help ensure the Jack stays in place on the Utility Rails.

10. Raise the four-post Lift (so that the Rolling Bridge Jack is off the ground) and engage it on Safety Locks.

If you put the Lift on a Safety Lock in Step 1, you can ignore this step.

⚠ WARNING Do not start using the Rolling Bridge Jack until you have personally made sure the Lift is securely engaged on Safety Locks.

11. Check the clearance and movement of the Rolling Bridge Jack.

Make sure the Channel Rollers are centered in the Utility Rail Channel at all points along the usable portion of the Utility Rail.

12. If necessary, make adjustments to ensure proper operation.

Do not use your Rolling Bridge Jack until it is safe to do so!

Setting Up the Air-Operated Hydraulic Pump

Your Rolling Bridge Jack comes with an Air-Operated Hydraulic Pump, which provides air pressure so you can raise and lower the Jack.

It is your responsibility to supply air pressure to the Pump.

The Air-Operated Hydraulic Pump comes from the factory with Hydraulic Fluid. You do not need to add any at this point, unless the Hydraulic Fluid has leaked out. Checking the Hydraulic Fluid level is described in the next section.

Air pressure should be set to 20 cubic feet per minute (.57 cubic meters per minute) and 100 psi (7 bar).

Do not exceed 125 psi (8.6 bar) at any point; you could damage the Air-Operated Hydraulic Pump.

⚠ WARNING Before performing installation or maintenance, release the air pressure currently in the system, then disconnect the pump at the Air Intake Valve. If you do not release the air pressure in the system, anyone working on the Jack or nearby could be injured (or, in rare cases, killed) by an unexpected release of energy.

To set up your Air-Operated Hydraulic Pump:

1. Remove the thread protector from the Air Intake Valve on the Pump.

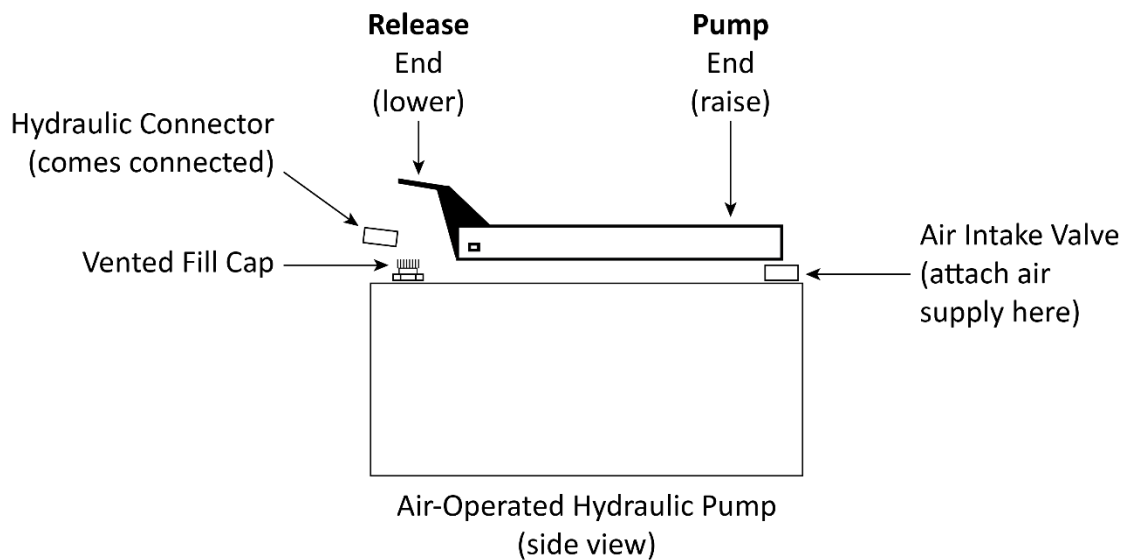

2. Install a threaded fitting (not supplied) that is compatible with your air supply into the Air Intake Valve.
3. Connect your air pressure supply to the threaded fitting you just installed on the Pump.

⚠ CAUTION An appropriate Air Line regulator and water separator must be installed on the air pressure supply line. ***Failure to install these items could lead to damage and voids the warranty on pneumatic components.***

4. Loosen the Vented Fill Cap approximately one turn counterclockwise before starting normal operation (it was tightened for shipment).

Preparing for Operation

To prepare the Rolling Bridge Jack for normal operation, you need to:

- Check the fluid reservoir on the Air-Operated Hydraulic Pump; it should come full from the factory, but occasionally the fluid can leak.
- Perform an operational test to make sure the Jack is working normally.

The fluid reservoir of your Rolling Bridge Jack was filled at the factory. Nevertheless, before using it, you should check the reservoir to make sure it still has adequate Hydraulic Fluid.

⚠ CAUTION Do not run the Air-Operated Hydraulic Pump without fluid; you will damage it.

Approved fluids are any general purpose ISO-32, ISO-46, or ISO-68 Hydraulic Fluid or approved ATF fluids such as Dexron III, Dexron VI, Mercon V, Mercon LV, or any Synthetic Multi-Vehicle ATF.

To check the fluid reservoir of the Air-Operated Hydraulic Pump:

1. Remove the Vented Fill Cap.
2. Insert a dipstick or piece of plastic into the tank until it hits the bottom.
3. Remove the dipstick or piece of plastic and measure the amount of fluid.
The fluid level should be from 3.35 to 3.5 inches deep.
4. If the current level is below 3.35 inches, add approved fluid until it is between 3.35 and 3.5 inches.
5. If the current level is already between 3.35 and 3.5 inches, no action needs to be taken.
6. Reinstall the Vented Fill Cap.

You do not need a Vehicle on the Jack to test it.

To test your Rolling Bridge Jack:

⚠ WARNING When raising or lowering your Jack, keep body parts, especially your hands, away from the Scissor Structure, the Adjustable Arms, and all pinch points. You could be injured if you are not careful.

1. Press and hold the **PUMP** end of the pedal to begin raising the Rolling Bridge Jack.
2. When the Rolling Jack reaches the desired height, release the **PUMP** end.

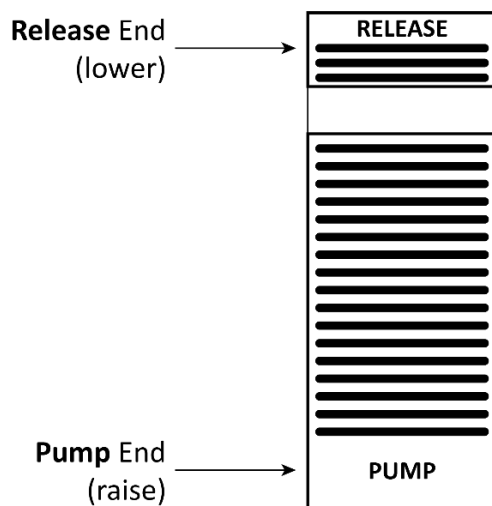

If the Rolling Bridge Jack does not go up, refer to [Troubleshooting](#).

3. Press and hold the **RELEASE** end to lower the Jack down onto the closest Safety Lock.
4. Release the **RELEASE** end of the Pump when the Safety Lock engages on the Safety Lock Pin.

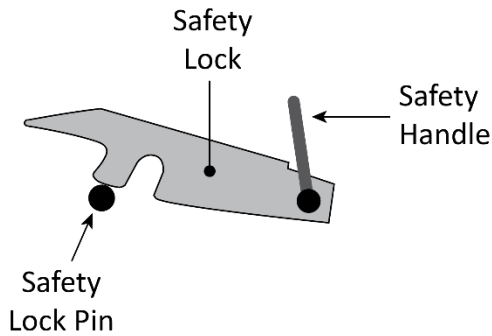

Not Engaged on Safety Lock

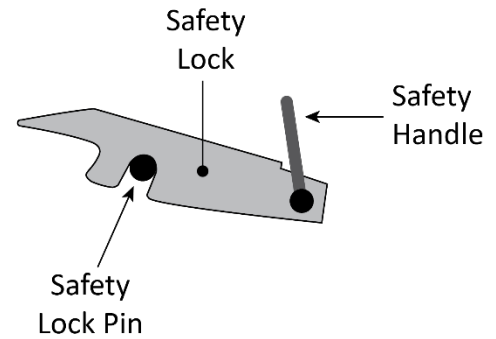

Engaged on Safety Lock

This drawing shows, on the Left, the Jack between the two Safety Lock positions; the Safety Lock is **not** engaged on the Safety Lock Pin. On the right, however, the Safety Lock is engaged on the Safety Lock Pin.

⚠ WARNING Only leave your Rolling Bridge Jack engaged on a Safety Lock or fully lowered.

5. To lower the Rolling Bridge Jack from a Safety Lock: press the **PUMP** end of the pedal to move it up and off the Safety Lock Pin, pull the Safety Handle away from the Safety Lock (towards the RBJ Structure), then press and hold the **RELEASE** end of the pedal.

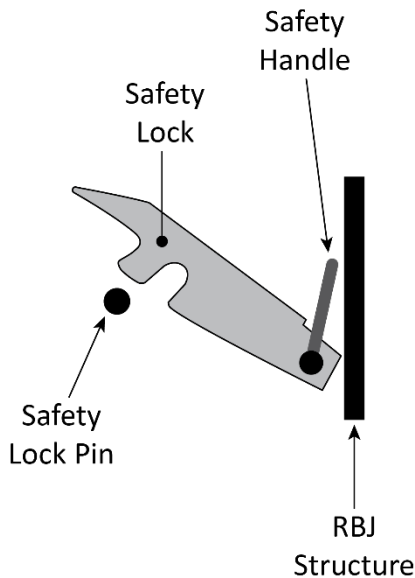

The Rolling Bridge Jack begins lowering. Because *the Safety Handle is holding the Safety Lock up and away from the Safety Lock Pin*, the Safety Lock will not engage on the Safety Lock Pin.

6. When the Jack is fully lowered, wait two seconds, then release the **RELEASE** end of the pedal.

Assuming the test went fine, your Rolling Bridge Jack is ready for normal operation.

If there were issues, resolve the issues before beginning normal operation. You can refer to **Troubleshooting** for additional information.

Operation

This section covers normal operation of your Rolling Bridge Jack.

Safety Rules

Important: Your safety is dependent on reading, understanding, and implementing these Safety Rules. ***Do not skip over them; read them carefully and follow them!***

To use your Rolling Bridge Jack safely:

- Never stand under or walk under a Rolling Bridge Jack when the Lift is raised, whether there is a Vehicle on the Jack or not. **Safety first: walk around the Lift, not under it!**
- Check daily to make sure all Rollers are sitting correctly in the Utility Channel. If one or more Rollers come out of the Utility Channel, it could fall.

⚠ DANGER If you see any of the Rollers out of the Utility Channel or moving strangely, immediately move all persons away from the Lift and the Rolling Bridge Jack. When everyone is out of the way, carefully lower the Lift to the ground (if it is raised) and drive the Vehicle off (if there is a Vehicle on the Lift), as long as these things can be done safely. When the Lift is fully lowered, put the Rollers back into the Utility Channel, then make sure the Adjustment Bolts are installed and operating correctly. Do not attempt to put the Rollers back into the Utility Channel from underneath the Rolling Bridge Jack.

- After moving or using your Rolling Bridge Jack, check to make sure the Rollers are sitting correctly in the Utility Channel.

⚠ WARNING Use care when using your Rolling Bridge Jack. If it falls when the Lift is raised, it can damage the Jack, the ground underneath, or cause significant injury to anyone underneath it. **BendPak strongly recommends no one, ever, walk underneath your Rolling Bridge Jack when the Lift is raised.**

- Always keep the Utility Rail Channels clean. If there are liquid spills, wipe them up. If there is debris, clean it up. If anything other than your Rolling Bridge Jack is in the Utility Rail Channels, move those things out of the way.
- Before lowering the Lift, check underneath it to make sure there are no obstructions on the ground under the Rolling Bridge Jack. If there is something underneath the Rolling Bridge Jack, move it out of the way. The issue here is that if the Jack hits an obstruction on the ground, it could push the Jack out of position or off the Utility Rail, increasing the chances that it could fall in the future.
- Before driving a Vehicle onto the Lift, make sure the Rolling Jack is **fully** lowered and the Pads are removed; you do not want the underside of the Vehicle to contact any part of the Jack.
- Before and after driving a Vehicle onto the Lift, make sure the Rollers are sitting correctly in the Utility Channel.
- If a Vehicle accidentally knocks the Rolling Bridge Jack when being driven either onto or off of the Lift, the Jack may no longer be secure. Check to make sure the Rollers are sitting correctly in the Utility Channel, the Adjustment Bolts are in place and operating normally, and the Rolling Bridge Jack is not damaged. If you find any of these situations, take the Jack out of service and fix the issues before resuming use of the Rolling Bridge Jack.

Raising and Lowering

This section describes how to raise and lower your Rolling Bridge Jack.

To raise a Vehicle:

1. Drive the Vehicle onto the Lift.

⚠ WARNING Make sure the Jack is fully lowered and the Pads are removed; you do not want them to hit the underside of the Vehicle as it is driven onto the Lift. If a Vehicle does ever hit any part of the Rolling Bridge Jack while being driven onto or off of the Lift, make sure the Rolling Bridge Jack has not been damaged and that all Channel Rollers are correctly seated in the Utility Rail Channel.

2. Position the tires of the Vehicle in the center of each Runway.
3. Set the parking brake on the Vehicle and use a wheel chock to hold the Vehicle in position.
4. Check the Utility Rail Channels to make sure nothing is in them that could obstruct the movement of the Rolling Bridge Jack.
5. Check the area to make sure everyone is clear of the Lift and the Rolling Bridge Jack; make sure there are no obstructions above the Vehicle.
6. Position the Adjustable Arms of the Rolling Bridge Jack so the Pads are under the Vehicle's axles or lifting points.

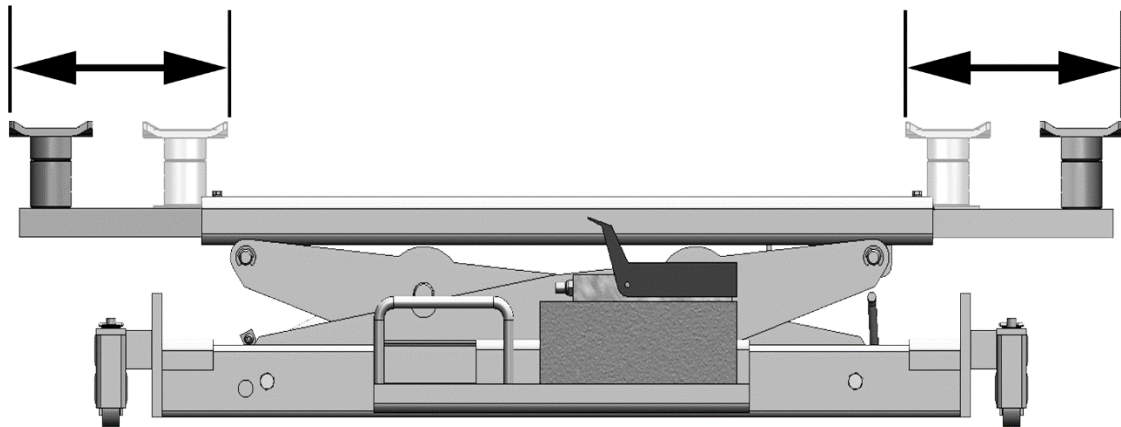

⚠ WARNING Make sure to lift the Vehicle on the axles or on the correct lifting points. Lifting at the wrong location could potentially damage the Vehicle and/or the Rolling Bridge Jack.

7. Press and hold the **PUMP** end of the pedal to begin raising the Rolling Bridge Jack.

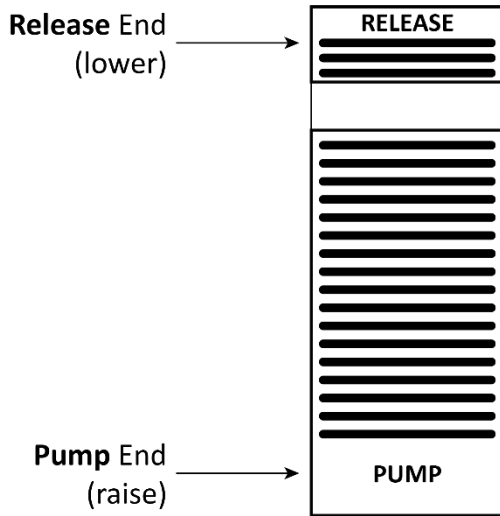

8. When the Rolling Bridge Jack reaches the desired height, release the **PUMP** end, then press and hold the **RELEASE** end to engage the Rolling Bridge Jack on the nearest Safety Locks.
9. Release the **RELEASE** end two seconds after the Jack settles on the Safety Locks.

To lower a Vehicle:

1. Press the **PUMP** end of the pedal for about two seconds; this raises the Jack, moving the Safety Locks up and off the Safety Lock Pins.

It is difficult to move the Safety Handle out of the way if the Jack is engaged on its Safety Locks.

2. Pull the Safety Handle up out of the way (this creates enough room for the Safety Locks to pass over the Safety Lock Pins).
3. While continuing to hold the Safety Handle up, press and hold the **RELEASE** end of the pedal.

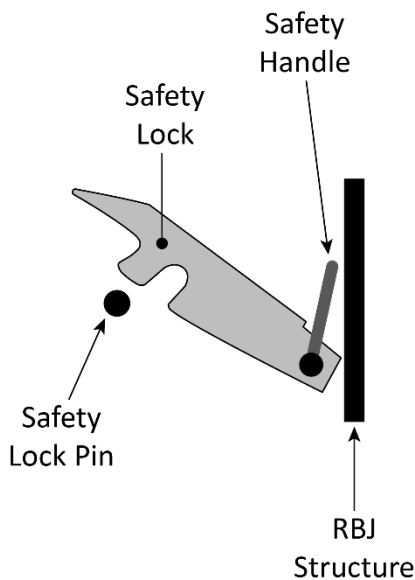

The Rolling Bridge Jack begins lowering.

4. When the Jack is fully lowered, release the **RELEASE** end of the pedal.

Moving a Rolling Bridge Jack

Tips for moving a Rolling Bridge Jack:

- Do **not** try to move a Rolling Bridge Jack if it has a Vehicle raised on it.
- The easiest way to move a Rolling Bridge Jack is to use its Handles when the Lift is lowered and there is no Vehicle on the Lift.
- If you know what Vehicle you are going to be raising on a Rolling Bridge Jack, move the Jack(s) to where you think the axles or lifting points will hit **before** driving the Vehicle onto the Lift.
- To move a Rolling Bridge Jack while the Lift is raised, use the Handles, but **do not stand directly under the Jack**.
- Before moving a Rolling Bridge Jack while the Lift is raised, check to make sure the Rollers are sitting correctly in the Rail Utility Channel, depending on model. Also check to make sure the Adjustment Bolts are installed and working normally.

 **WARNING** The safest way to move a Rolling Jack is when the Lift is fully lowered and no Vehicle is on the Rolling Jack or on the Lift. BendPak strongly recommends always moving your Rolling Jack with the Lift fully lowered.

- **Do not stand or work under a Rolling Bridge Jack on a raised Lift.**

Additional Operating Information

Keep the following in mind when operating your Rolling Bridge Jack:

- Check the weight of a Vehicle before attempting to lift it. Do not guess. Do **not** exceed the rated load capacity of the Rolling Bridge Jack.
- Pads must always be used; make sure they are correctly positioned under the axles or the lifting points of the Vehicle you are raising. Do not raise a load without Pads.
- Visually inspect your Rolling Bridge Jack before each use. Do not use it if you find damage or severe wear. Make sure the Channel Rollers are in the Utility Rail Channel.
- Do not rock the Vehicle while it is raised or remove items that could cause excessive weight shift.
- Keep the Utility Rail Channels clean and free from debris.

Hydraulic Power System Warnings

 **WARNING** Failure to observe these precautions can result in serious personal injury, including, in rare cases, death.

- The Air-Operated Hydraulic Pump must be correctly connected to the Rolling Bridge Jack before raising a Vehicle or applying pressure.
- Do not attempt to connect or disconnect hose couplers while a Vehicle is raised or while the hydraulic system is under pressure.
- Use every precaution to guard against dirt getting into the Lift or the Air-Operated Hydraulic Pump.
- Keep bare hands away from Hydraulic Fluids.
- When dealing with Hydraulic Fluids, observe the safety instructions of the manufacturer.
- Use protective equipment (like safety goggles, protective gloves, suitable working clothes, safety boots, and so on) when dealing with the hydraulic system.
- If Hydraulic Fluid comes into contact with the eyes, gets into the bloodstream, or is swallowed, seek immediate medical attention.

Maintenance

⚠ WARNING: Before performing **any** maintenance, remove air pressure from the system, then disconnect the air pressure supply from the Air-Operated Hydraulic Pump.

To maintain your Rolling Bridge Jack:

- Keep the Rolling Bridge Jack clean; wipe up any oil spills. Do not let dirt get into the hydraulic system.
- **Daily:** Make a visual inspection of all moving parts and check for damage or excessive wear. Replace any damaged or worn parts before the Jack is put back into operation.
- **Daily:** Make sure the Safety Locks are in good operating condition. Do not use your Rolling Bridge Jack if the Safety Locks are damaged or excessively worn.
- **Daily:** Inspect Pads for damage or excessive wear. Replace as required with BendPak parts.
- **Weekly:** Lubricate all Rollers with general purpose oil or WD-40.
- **Weekly:** Check all hose connections, bolts, and pins to make sure they are properly mounted.
- **Weekly:** Lubricate the Safety Lock pivot points with general purpose oil or WD-40.
- **Weekly:** Check (and tighten, if necessary) the Cylinder Bolt.

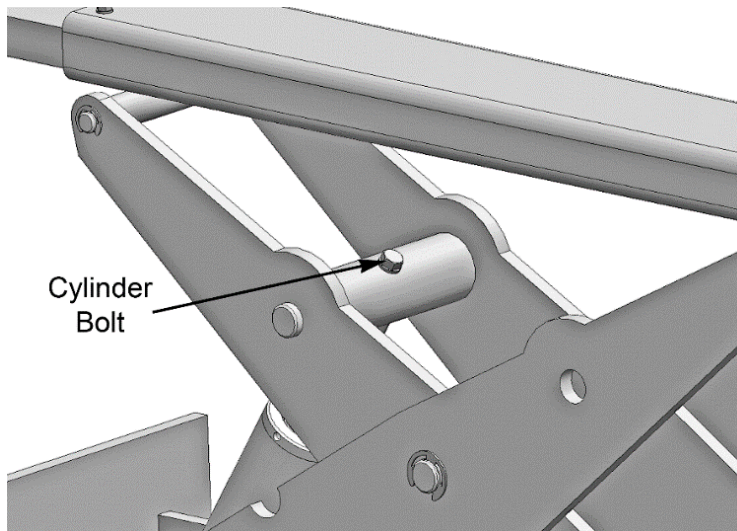

- **Every other month:** Check the Air-Operated Hydraulic Pump fluid level and refill if required.
- **As needed.** Replace all caution, warning, and safety-related labels if illegible or missing.
- **As needed.** Reorder labels and worn or damaged parts from BendPak.

To maintain Hydraulic Fluid:

1. Remove the Vented Fill Cap.
2. Insert a dipstick or piece of plastic into the tank until it hits the bottom.
3. Remove the dipstick or piece of plastic and measure the amount of fluid.
The Hydraulic Fluid level should be from 3.35 to 3.5 inches deep.
4. If the current level is below 3.35 inches, add Hydraulic Fluid until it is above 3.35 inches.

Disposing of Hydraulic Fluid

Used Hydraulic Fluid cannot be thrown in the regular trash or dumped into the environment. This pollutes the environment and is illegal.

Instead, take it to a recycling center. Used/dirty Hydraulic Fluid can be cleaned and re-used.

Important: If your Hydraulic Fluid is **contaminated** (by being mixed with other fluids such as antifreeze, gasoline, or solvents), you must treat it like a hazardous waste and take it for disposal at an appropriate facility. Contaminated is different than used/dirty.

In summary:

- If you have dirty/used Hydraulic Fluid, take it to a fluid recycling center.
- If you have contaminated Hydraulic Fluid, take it to a hazardous waste collection facility.

If you do not know how to find an appropriate facility, go to earth911.com or look for resources in your state or local area.

Troubleshooting

This section describes how to troubleshoot your Jack.

Issue	Action to Take
Jack does not lift load.	Make sure load is not over the Jack's rated capacity. Make sure the Jack is getting appropriate air pressure from the air supply. Make sure the Air-Operated Hydraulic Pump has sufficient Hydraulic Fluid. Make sure dirt has not gotten into the hydraulic system. If it has, replace the Hydraulic Fluid and clean the hydraulic system.
Jack does not move along Utility Rail.	Make sure the Utility Rail Channels and Lips are clear of obstructions. Make sure Rolling Bridge Jack is correctly situated in the Utility Rail Channel. Check with BendPak to make sure the Rolling Bridge Jack is installed on an approved Lift.
Jack raises load but does not stay up.	Make sure you put the Rolling Bridge Jack onto a Safety Lock position when the load is at the desired height. The Rolling Bridge Jack is meant to raise and lower loads; it is not designed to hold a load indefinitely unless the Jack is engaged on its Safety Locks. Make sure the Rolling Bridge Jack is not leaking Hydraulic Fluid.

If you continue to have an issue, contact your dealer or BendPak at **(800) 253-2363**.

Accessories

Optional AK-14 Integrated Rolling Bridge Air Line Kit

Mounts and secures your air line to your Lift's Runways, creating a handy air line solution for your Rolling Bridge Jacks.

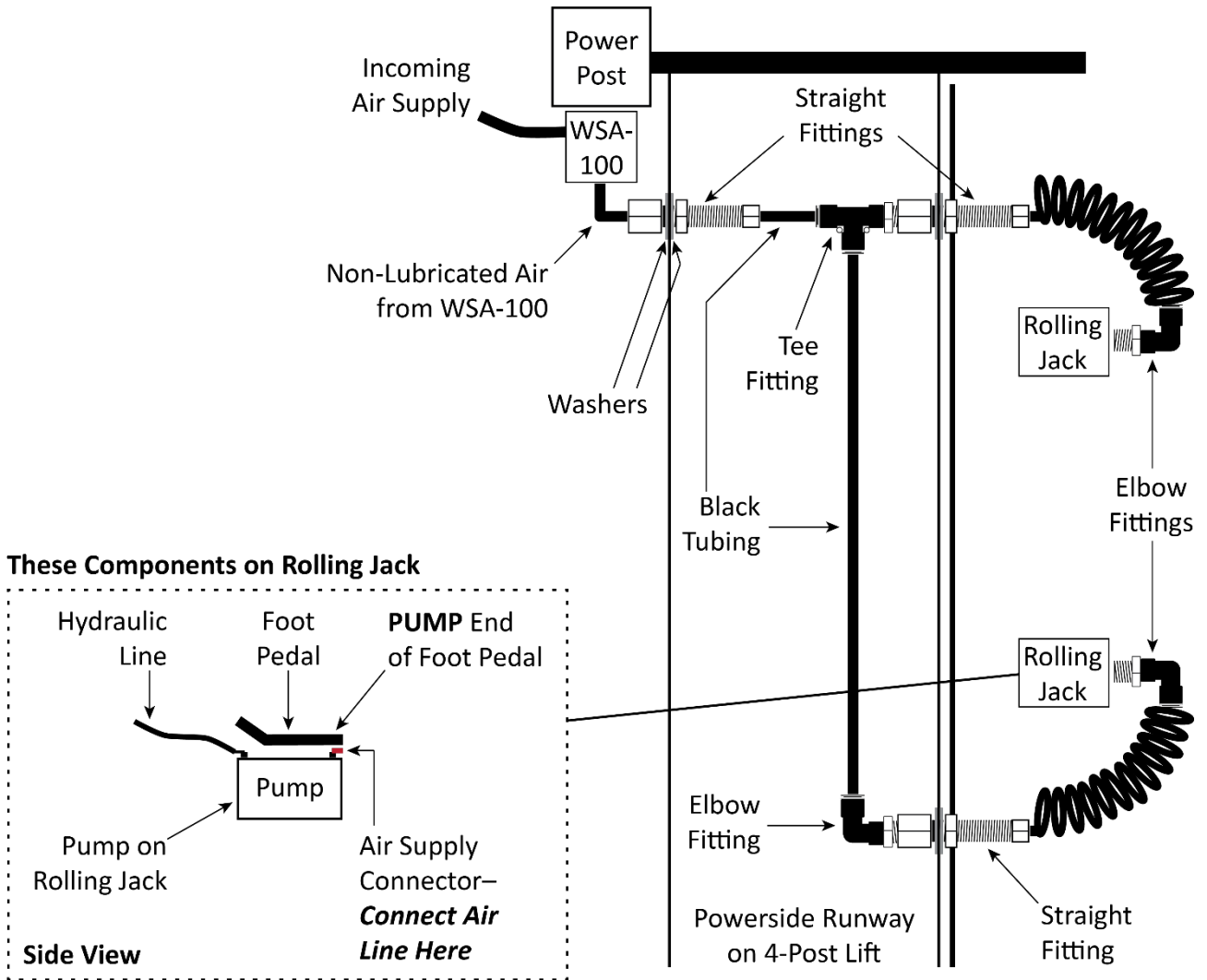

Visit [the website page for the Air Line Kit](#) for more information.

Labels

A

⚠ WARNING	<p>SERVICE REQUIREMENT EVERY 30-DAYS</p> <p>Keep entire jack and pump unit clean and free of debris. Lubricate both sides of all moving parts and pivot points on jack unit with multi-purpose lithium based grease, penetrating oil or 90-wt gear oil. Use enough lubrication to properly maintain all moving parts, but avoid over application. Apply silicone lubricant to smaller items such as handles and lock hinges. Always promptly remove excess grease and debris from jack unit and pump unit. If you choose to have this equipment serviced by a service technician, always perform a personal inspection of all points to be sure nothing was overlooked. Warranty will be void on this equipment if service maintenance is not performed on a regular basis.</p> <p style="text-align: right; font-size: small;">PN # 590532</p>	
------------------	--------------------------------------------------------------------------------------------------------------------------------------------------------------------------------------------------------------------------------------------------------------------------------------------------------------------------------------------------------------------------------------------------------------------------------------------------------------------------------------------------------------------------------------------------------------------------------------------------------------------------------------------------------------------------------------------------------------------------------------------------------------------------------------------------------------------------------------------------------	--

B

⚠ CAUTION!
<p>IMPROPER USE OF THIS ROLLING JACK MAY RESULT IN SERIOUS BODILY HARM!</p> <p>Always ensure that this rolling jack is positioned correctly on the runway rail assembly BEFORE raising the lift or working on or near the vehicle. KEEP HANDS CLEAR of all pinch points. NEVER use lift adapters other than those specifically designed for this jack.</p> <p style="text-align: right; font-size: small;">PN 5905190</p>

C

⚠ WARNING	<p>USE DRY AIR SOURCE ONLY</p> <p>Warranty will be void on this equipment if water contamination is found apparent. ALWAYS drain air compressor tank daily or use in-line dryer.</p> <p style="text-align: center; font-size: small;">SERVICE PARTS AND LABOR NOT COVERED UNDER WARRANTY IF RUST OR CORROSION IS PRESENT.</p>	<p>The pump unit on this jack was not designed to be used as a load holding device, jack must be raised to a locked position at all times. The manufacturer recommends installing an automatic air line oiler in the air inlet line as close to the pumping unit as possible. Air pressure must be regulated to 125 P.S.I. MAX. Pump unit must be kept clean to prevent contamination and pressure loss.</p> <p style="text-align: right; font-size: small;">PN 5905190</p>
------------------	----------------------------------------------------------------------------------------------------------------------------------------------------------------------------------------------------------------------------------------------------------------------------------------------------------------------------------------------------	-----------------------------------------------------------------------------------------------------------------------------------------------------------------------------------------------------------------------------------------------------------------------------------------------------------------------------------------------------------------------------------------------------------------------------------------------------------------------------

E

⚠ WARNING
<p>ALWAYS make sure rollers are properly positioned on runway utility rails and all ADJUSTMENT BOLTS are tightened before use or serious injury may result. READ PRODUCT MANUAL BEFORE USING THIS JACK.</p>
<p style="text-align: center; font-size: small;">Adjustment Bolts</p> <p style="text-align: right; font-size: x-small;">PN K0000X</p>

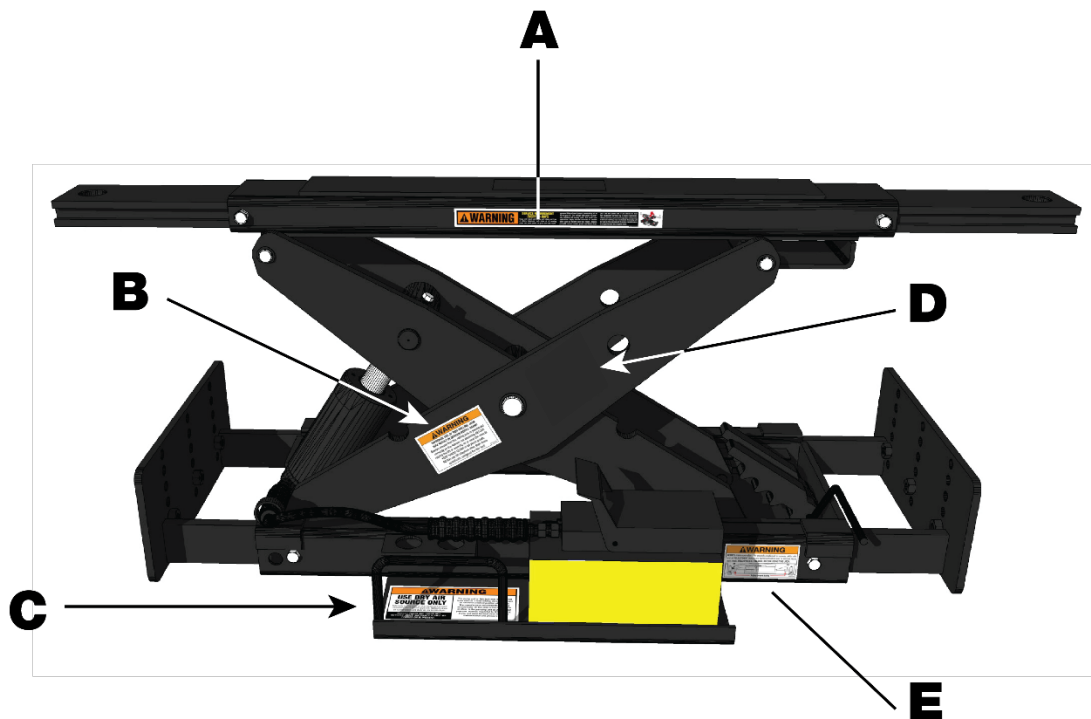

Parts Sheets

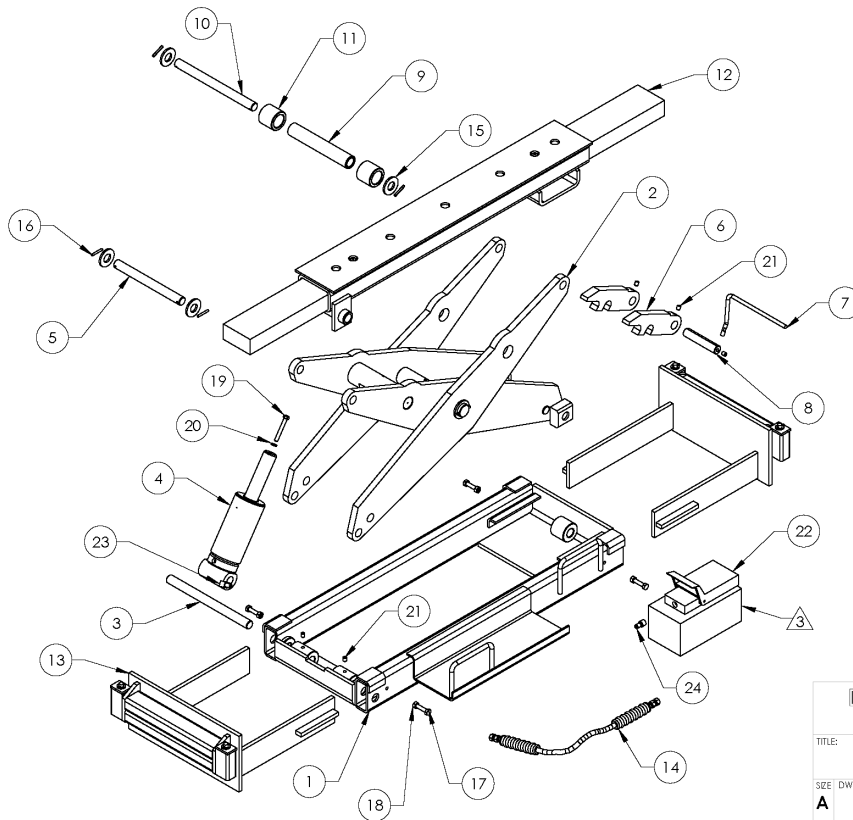

BendPak
1645 LEMONWOOD DR.
SANTA PAULA, CA 93060

TITLE: **RBJ1 5000 LIFT SUPERSTRUCTURE**

SIZE DWG. NO. **A 5205007** REV **M**

SCALE: 1:12 SHEET 2 OF 2

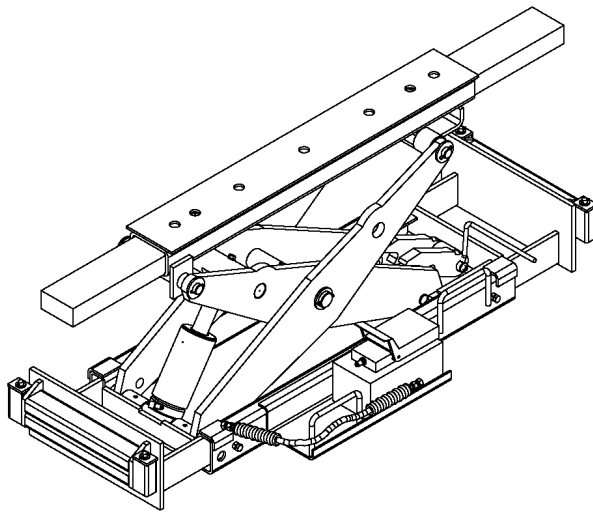

ITEM NO	PART NUMBER	DESCRIPTION	QTY	REV
1	5600363	RBJ1 5000 BASE WELDMENT	1	E
2	5215181	RBJ1 5000 SCISSOR ASSEMBLY	1	J
3	5210409	RBJ1 5000 CYLINDER PIVOT PIN	1	B
4	5502016	CYLINDER ASSEMBLY Ø3.0 x 4.375, EXTENDED ROD	1	D
5	5746103	RBJ1 5000 UPPER ROLLER SHAFT	1	B
6	5300913	RBJ1 5000/18000/25000 SAFETY	2	B
7	5300871	RBJ1 5000/18000/25000 SAFETY HANDLE	1	C
8	5746155	RBJ1 5000/18000/25000 SAFETY PIN	1	B
9	5716102	RJ/RBJ1 5000 LONG UPPER TUBE SPACER	1	C
10	5505102	RJ/RBJ1 5000 UPPER ARM PIVOT PIN	1	C
11	5716101	RJ/RBJ1 5000 SPACER	2	C
12	5210181	RBJ1 5000 TOP EXTENSION ASSEMBLY	1	C
13	5210217	RBJ1 5000 ARM EXTENSION ASSEMBLY	2	E
14	5570806	RJW SERIES HOSE ASSY Ø6.4mm x 600mm DS	1	E
15	5746154	RBJ1 5000 BEARING WASHER	4	B
16	5505136	SPRING PIN M5 x 40	4	-
17	5530302	HHB M10 x 1.5 x 40 FULLY THREAD	4	-
18	5535998	NUT M10 x 1.5	4	-
19	5530191	HHB 3/8"-16 x 2-3/4" GR8/CL 10.9	1	-
20	5545130	WASHER 3/8" SL	1	-
21	5530054	SSS M10x1.5x12	5	-
22	5585735	AIR HYDRAULIC PUMP YELLOW RBJ1 5000 PSI:8500	1	-
23	5550086	FTG ELB -04 NPT x -04 JIC	1	-
24	5550493	FTG RST -04 JIC x -06 NPT x .062 ID	1	-

DO NOT SCALE DRAWING

NAME _____ DATE 11/19/2015

DRAWN TM 11/19/2015

CHECKED CA 4/24/2019

THIRD ANGLE PROJECTION

PROPRIETARY AND CONFIDENTIAL
THE INFORMATION CONTAINED IN THIS DRAWING IS THE SOLE PROPERTY OF BENDPAK INC. ANY REPRODUCTION IN PART OR AS A WHOLE WITHOUT THE WRITTEN PERMISSION OF BENDPAK INC. IS PROHIBITED.

BendPak
1645 LEMONWOOD DR.
SANTA PAULA, CA 93060

TITLE: **RBJ1 5000 LIFT SUPERSTRUCTURE**

SIZE DWG. NO. **A 5205007** REV **M**

SCALE: 1:12 SHEET 1 OF 2

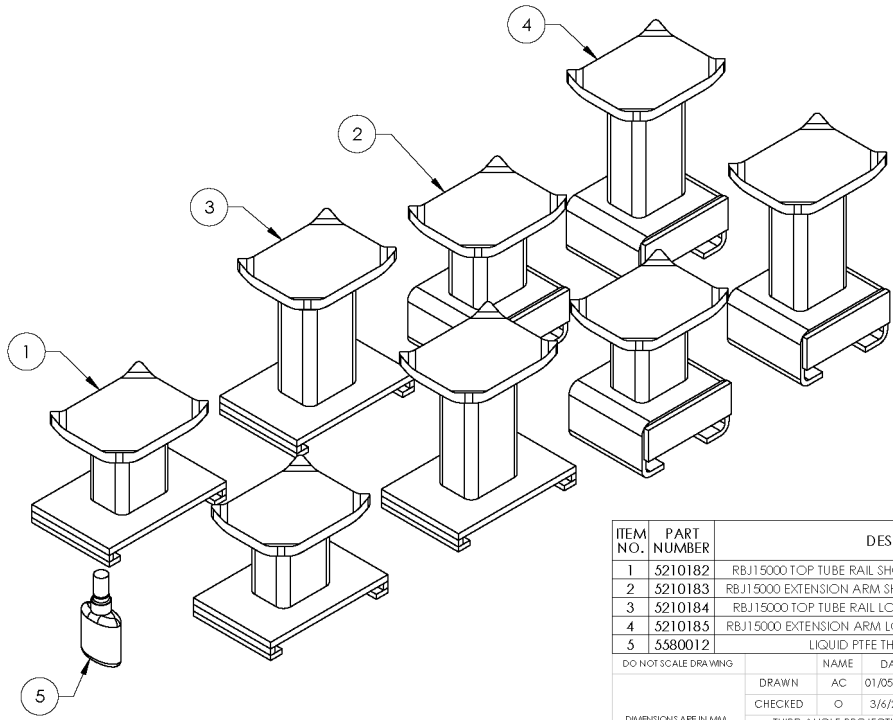
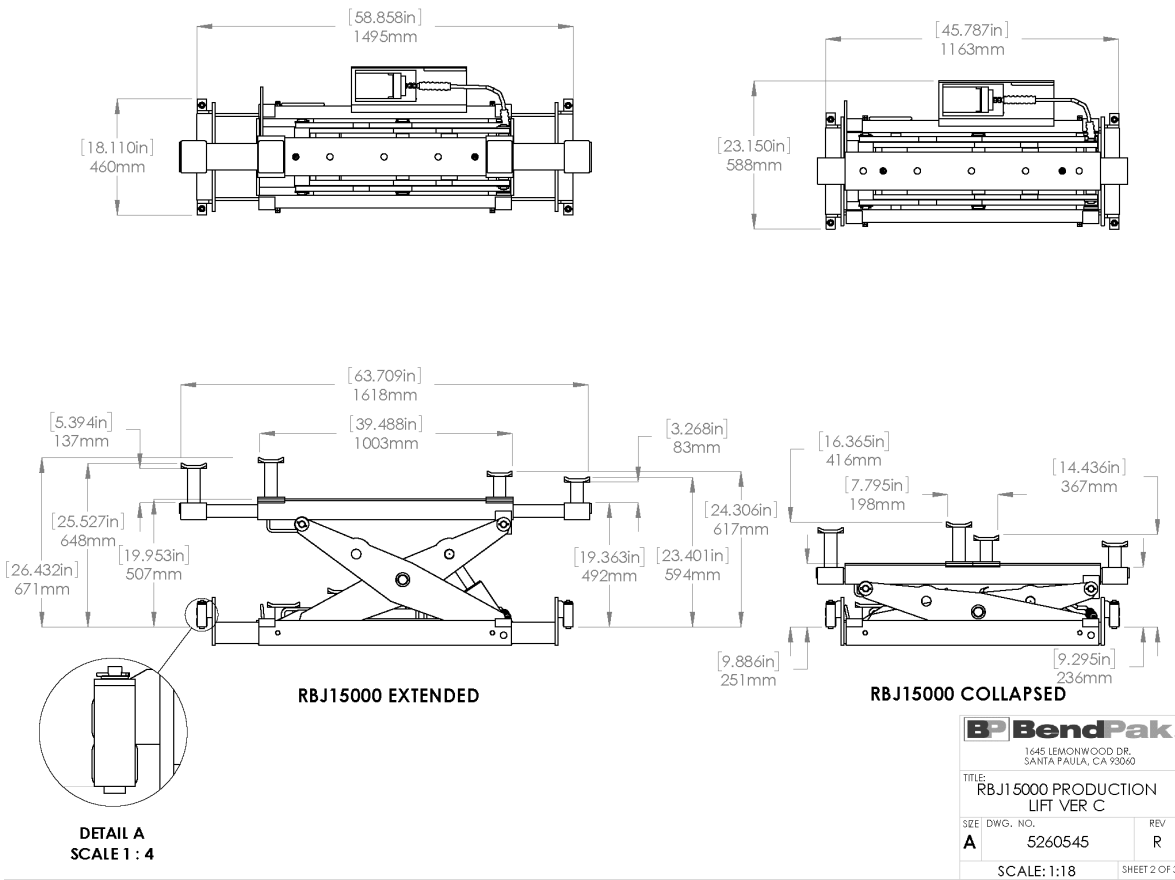

ITEM NO.	PART NUMBER	DESCRIPTION	QTY	REV
1	5210182	RBJ15000 TOP TUBE RAIL SHORT HEIGHT ADAPTER WELDMENT	2	A
2	5210183	RBJ15000 EXTENSION ARM SHORT HEIGHT ADAPTER WELDMENT	2	A
3	5210184	RBJ15000 TOP TUBE RAIL LONG HEIGHT ADAPTER WELDMENT	2	A
4	5210185	RBJ15000 EXTENSION ARM LONG HEIGHT ADAPTER WELDMENT	2	A
5	5580012	LIQUID PTFE THREAD SEALANT 4 .02	1	-

DO NOT SCALE DRAWING	NAME	DATE	BendPak 1645 LEMONWOOD DR. SANTA PAULA, CA 93060
	DRAWN	AC	
	CHECKED	O	3/6/2020
DIMENSIONS ARE IN MM	THIRD ANGLE PROJECTION		TITLE: RBJ15000 PARTS BOX
	SIZE	DWG. NO.	REV
	A	5250116	G
SCALE: 1:5			SHEET 1 OF 1

PROPRIETARY AND CONFIDENTIAL
THE INFORMATION CONTAINED IN THIS DRAWING IS THE SOLE PROPERTY OF BENDPAK, INC. ANY REPRODUCTION IN PART OR AS A WHOLE WITHOUT THE WRITTEN PERMISSION OF BENDPAK, INC. IS PROHIBITED.

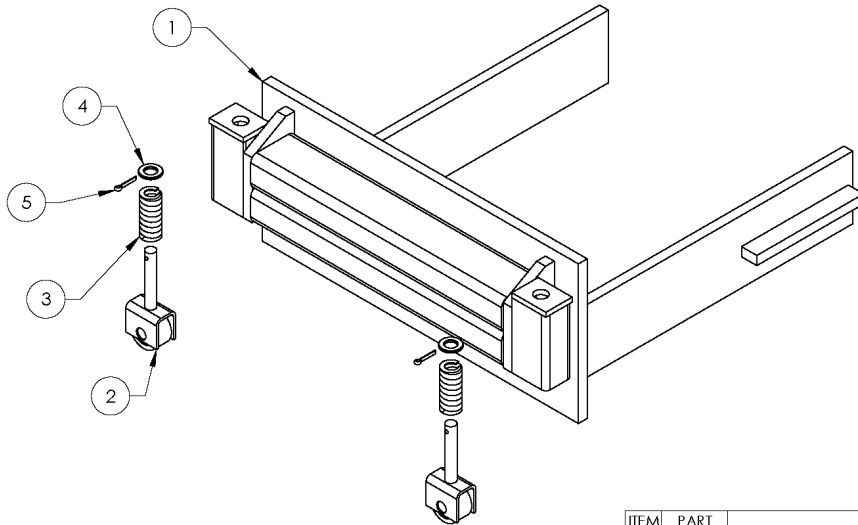

ITEM NO	PART NUMBER	DESCRIPTION	QTY	REV
1	5600362	RBJ15000 BASE EXTENSION ARM WELDMENT	1	C
2	5210219	RBJ45000 BYB/15000/18000/25000 RAIL ROLLER ASSEMBLY	2	D
3	5540027	COMPRESSION SPRING 22 x 50mm	2	A
4	5545347	WASHER, M12 FLAT WASHER	2	-
5	5505006	COTTER PIN Ø3.2 x 20mm	2	-

DO NOT SCALE DRAWING		NAME	DATE	 1645 LEMONWOOD DR. SANTA PAULA, CA 93060
DRAWN	TM	02/13/2015		
CHECKED	CA	4/24/2019		
DIMENSIONS ARE IN MM		THIRD ANGLE PROJECTION		TITLE: RBJ15000 ARM EXTENSION ASSEMBLY SIZE DWG. NO. A 5210217 REV E SCALE: 1:5 SHEET 1 OF 1

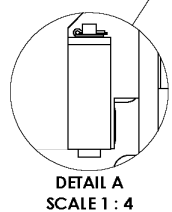
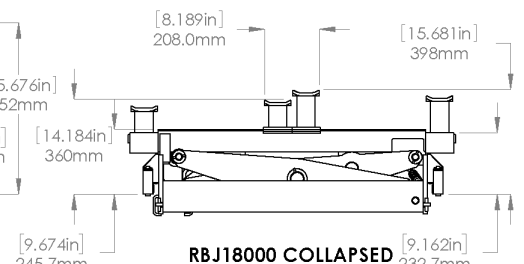
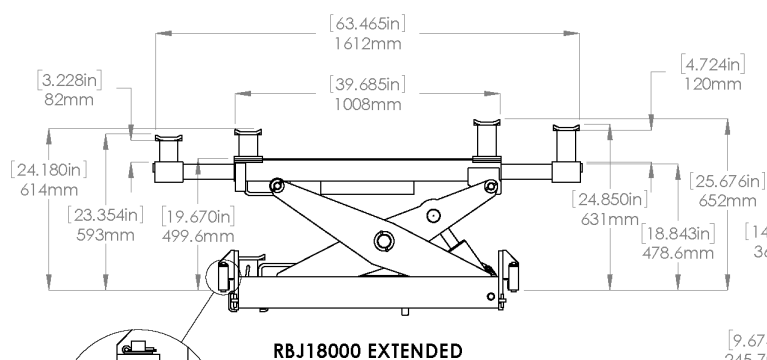
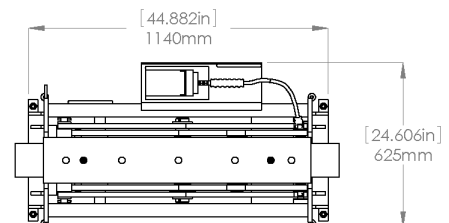
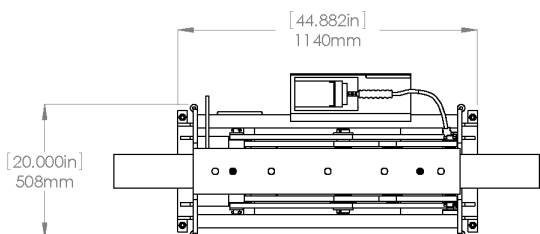

 1645 LEMONWOOD DR. SANTA PAULA, CA 93060	
TITLE: RBJ18000 PRODUCTION LIFT VER C	
SIZE DWG. NO. A 5260279	REV Q
SCALE: 1:18 SHEET 2 OF 3	

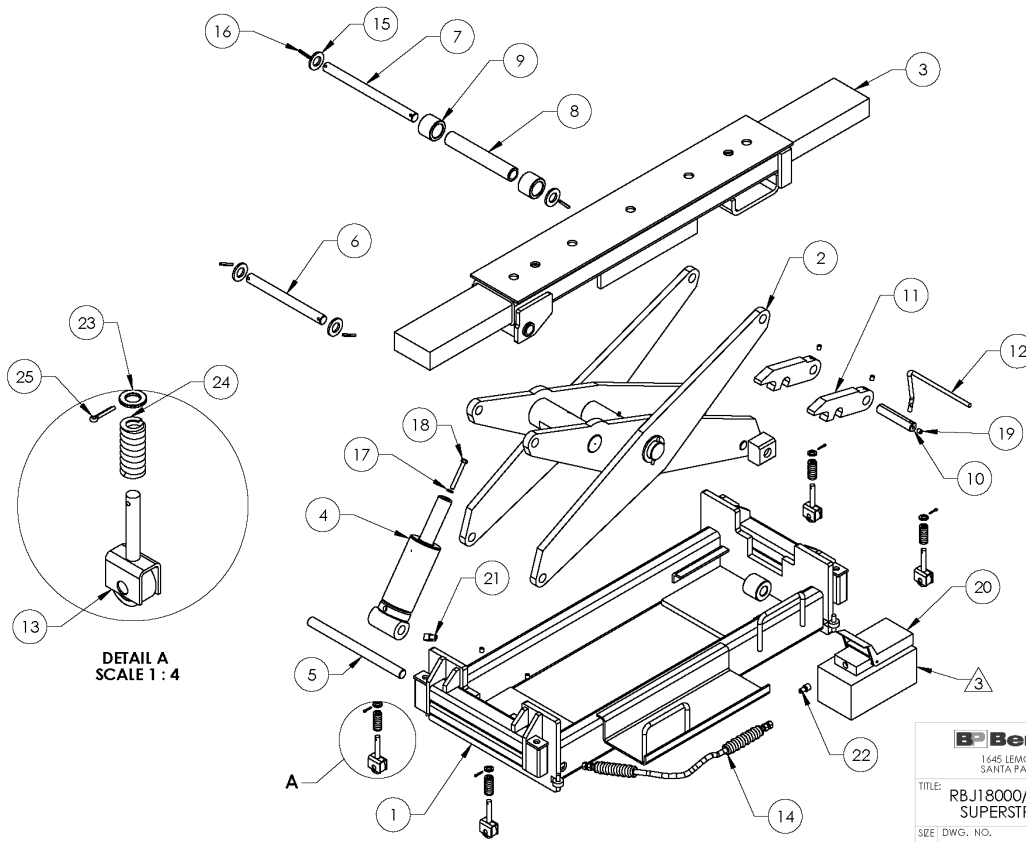

BendPak.
 1645 LEMONWOOD DR.
 SANTA PAULA, CA 93060

TITLE: RBJ18000/25000 LIFT SUPERSTRUCTURE

SIZE	DWG. NO.	REV
A	5205006	L

SCALE: 1:12 SHEET 2 OF 2

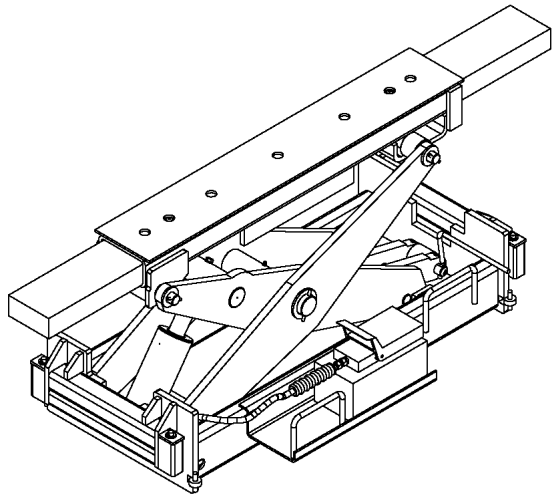

ITEM NO.	PART NUMBER	DESCRIPTION	QTY	REV
1	5600355	RBJ BASE WELDMENT	1	F
2	5215180	RBJ18000/25000 SCISSOR ASSEMBLY	1	J
3	5215456	RBJ18000/25000 UPPER EXTENSION ARM ASSEMBLY	1	C
4	5502167	CYLINDER ASSEMBLY Ø3.0 x 4.5	1	E
5	5745057	RBJ18000/25000 CYLINDER PIVOT PIN	1	B
6	5746628	R/J/RBJ18000/25000 SMALL UPPER PIVOT SHAFT	1	C
7	5746094	R/J/RBJ18000/25000 LONG UPPER PIVOT SHAFT	1	C
8	5755118	R/J/RBJ18000/25000 LONG UPPER TUBE SPACER	1	D
9	5746629	R/J/RBJ18000/25000 SPACER	2	C
10	5746155	RB.J15000/18000/25000 SAFETY PIN	1	B
11	5300913	RB.J15000/18000/25000 SAFETY	2	B
12	5300871	RB.J15000/18000/25000 SAFETY HANDLE	1	C
13	5210219	RBJ45000 BYB/15000/18000/25000 RAIL ROLLER ASSEMBLY	4	D
14	5570806	RJW SERIES HOSE ASSY Ø6.4mm x 600mm DS	1	E
15	5736508	R/J/RBJ18000/25000 RETAINING WASHER	4	C
16	5505106	SPRING PIN M6 x 50	4	-
17	5545130	WASHER 3/8" SL	1	-
18	5530133	HHB 3/8"-16 x 3" GRB/CL 10.9	1	-
19	5530054	SSS M10x1.5x12	5	-
20	5585736	AIR HYDRAULIC PUMP YELLOW RBJ18000/25000 PSI:9700	1	-
21	5550086	FTG ELB -04 NPT x -04 JIC	1	-
22	5550493	FTG RST -04 JIC x -06 NPT x .062 ID	1	-
23	5545347	WASHER, M12 FLAT WASHER	4	-
24	5540027	COMPRESSION SPRING 22 x 50mm	4	A
25	5505006	COTTER PIN Ø3.2 x 20mm	4	-

DO NOT SCALE DRAWING

NAME	DATE
TM	11/17/2015
CHECKED	CA
8/8/2019	

DIMENSIONS ARE IN MM

THIRD ANGLE PROJECTION

BendPak.
 1645 LEMONWOOD DR.
 SANTA PAULA, CA 93060

TITLE: RBJ18000/25000 LIFT SUPERSTRUCTURE

SIZE	DWG. NO.	REV
A	5205006	L

SCALE: 1:12 SHEET 1 OF 2

PROPRIETARY AND CONFIDENTIAL
 THE INFORMATION CONTAINED IN THIS DRAWING IS THE SOLE PROPERTY OF BENDPAK INC. ANY REPRODUCTION IN PART OR AS A WHOLE WITHOUT THE WRITTEN PERMISSION OF BENDPAK INC. IS PROHIBITED.

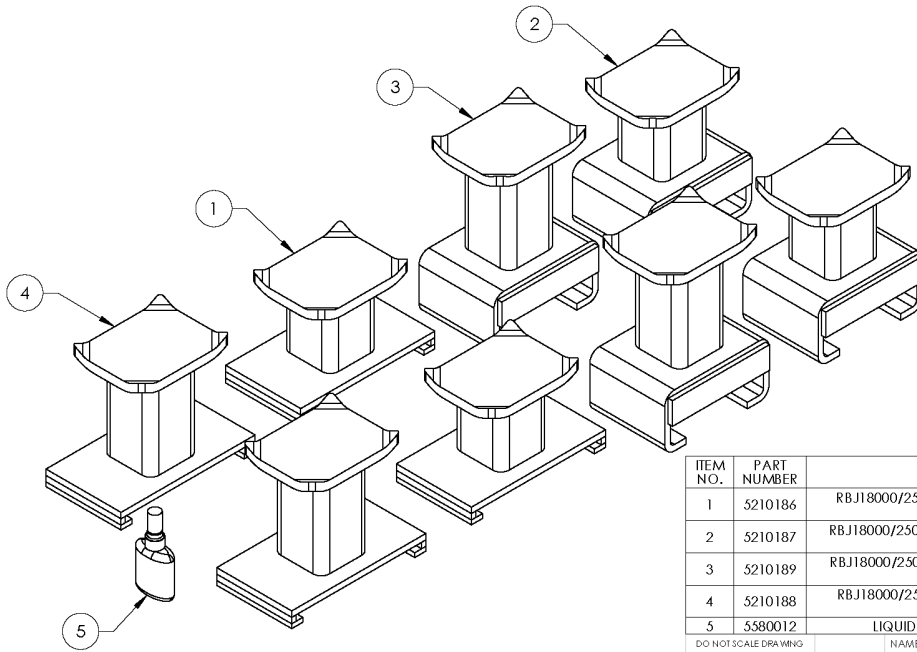

ITEM NO.	PART NUMBER	DESCRIPTION	QTY.	REV
1	5210186	RBJ18000/25000 TOP TUBE RAIL SHORT HEIGHT ADAPTER WELDMENT	2	A
2	5210187	RBJ18000/25000 EXTENSION ARM SHORT HEIGHT ADAPTER WELDMENT	2	A
3	5210189	RBJ18000/25000 EXTENSION ARM LONG HEIGHT ADAPTER WELDMENT	2	A
4	5210188	RBJ18000/25000 TOP TUBE RAIL LONG HEIGHT ADAPTER WELDMENT	2	A
5	5580012	LIQUID PTFE THREAD SEALANT 4 .oz	1	-

DO NOT SCALE DRAWING

DRAWN	AC	DATE	01/05/2010
CHECKED	O	DATE	3/6/2020

THIRD ANGLE PROJECTION

PROPRIETARY AND CONFIDENTIAL
THE INFORMATION CONTAINED IN THIS DRAWING IS THE SOLE PROPERTY OF BENDPAK INC. ANY REPRODUCTION IN PART OR AS A WHOLE WITHOUT THE WRITTEN PERMISSION OF BENDPAK INC. IS PROHIBITED.

BendPak
1645 LEMONWOOD DR.
SANTA PAULA, CA 93060

TITLE: RBJ18000/25000 PARTS BOX

SIZE DWG. NO. A 5250117 REV F

SCALE: 1:5 SHEET 1 OF 1

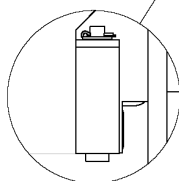
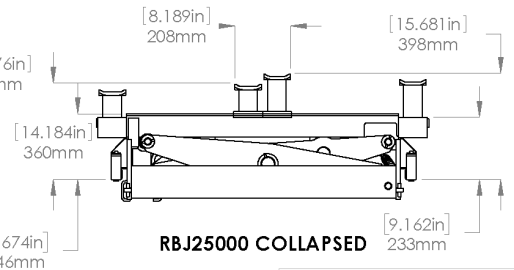
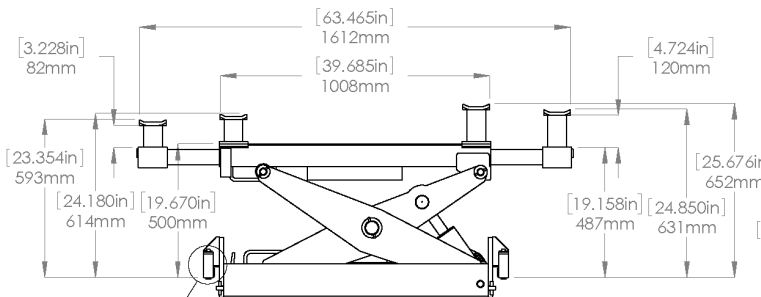
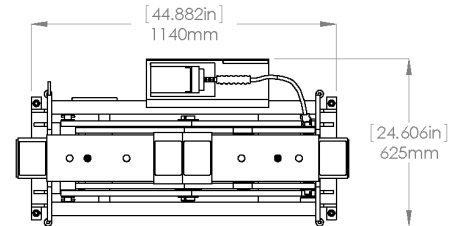
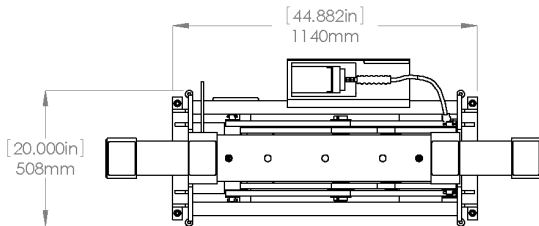

DETAIL A
SCALE 1 : 4

RBJ25000 EXTENDED

RBJ25000 COLLAPSED

BendPak
1645 LEMONWOOD DR.
SANTA PAULA, CA 93060

TITLE: RBJ25000 PRODUCTION LIFT VER C

SIZE DWG. NO. A 5260544 REV Q

SCALE: 1:18 SHEET 2 OF 3



1645 Lemonwood Drive
Santa Paula, CA, 93060 USA